Wireless 2-Gang Vibration Sensor, Spring Type

Wireless 2-Gang Vibration Sensor, Spring Type

Wireless Sensor Network Based on LoRa Technology



Copyright©Netvox Technology Co., Ltd.

This document contains proprietary technical information which is the property of NETVOX Technology. It shall be maintained in strict confidence and shall not be disclosed to other parties, in whole or in part, without written permission of NETVOX Technology. The specifications are subject to change without prior notice.

Wireless 2-Gang Vibration Sensor, Spring Type

Description

When the vibration sensor moves or vibrates, the R718DB2 can detect the vibration or movement signal, and transmit the detected data to other devices through the wireless network. It uses the SX1276 wireless communication module.

* R718DB2 is not suitable for the fast-vibrating environment.

Principle of Operation

When the shock sensor is touched by an external force to reach the corresponding vibration force or the moving speed reaches an appropriate centrifugal force, the module can detect the vibration signal or the movement signal.

Main Characters

- Apply SX1276 wireless communication module
- 2 section ER14505 batteries AA size (3.6V/section) parallel power supply
- Vibration detection
- The base is equipped with a magnet that can be attached to the magnetic substance
- IP Ratings: Main part- IP65/IP67 (Optional), Sensor-/IP67
- LoRaWAN™ Class A compatible
- Frequency Hopping Spread Spectrum (FHSS)
- Improved interference immunity
- Improved power management for longer battery life

Example Applications

- Equipment that needs to be detected vibration or movement

Wireless 2-Gang Vibration Sensor, Spring Type

Technical Specifications

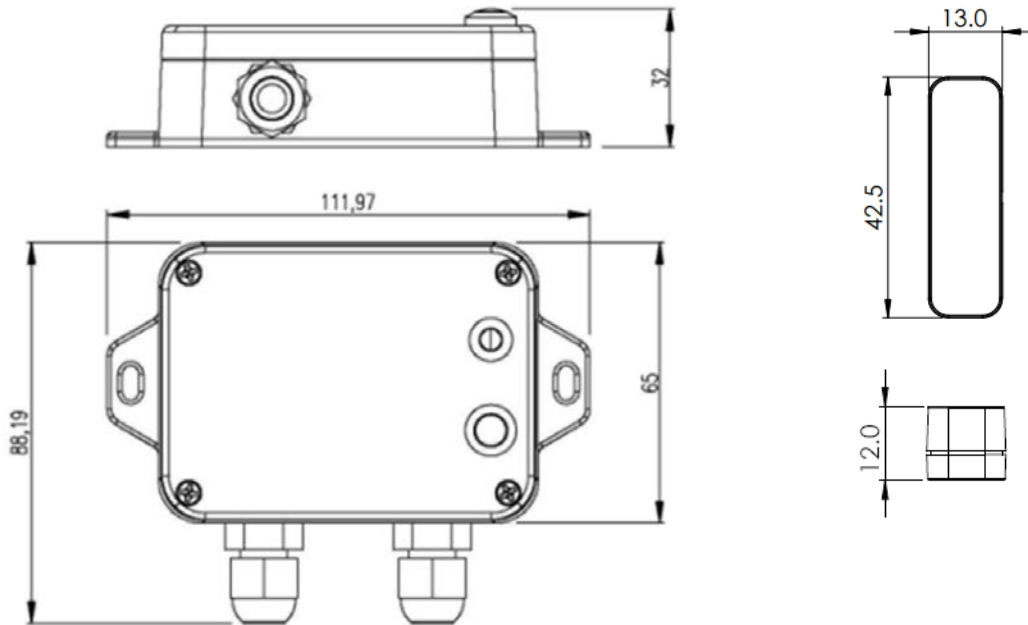

Unit: mm

Electric

Input Power	2 x 3.6V ER14505 AAsize lithium batteries
Operating Voltage	3.1v to 3.65v
Low Voltage Threshold	3.2v
Standby Current	23uA
Wakeup Current	When not transmitting / receiving LoRa data: 0.8mA-20 mA Module: 0.8mA to 8mA @ 3.3V
Receiving Current (max)	11mA @3.3V
Transmitting Current (max)	120mA/3.3V
Battery Voltage Accuracy	±0.1V

Wireless 2-Gang Vibration Sensor, Spring Type

Vibration Sensor

Vibration Sensor Case Size	L:43mm*W:13mm*H:12mm
Vibration Sensor Maximum Voltage	5V
Sensor Switch Life	Up to 200,000 times
Vibration Sensor Working Principle	When it is at rest, it is in the open state OFF state. When the external force is touched to reach the corresponding vibration force, or when the moving speed reaches the appropriate centrifugal force, the conductive pin will instantly reach the ON state. When the external force disappears, the switch returns to the OFF state.
Cable Length	1m

Frequency

TX Power	US915 20dbm ; AS923 16dbm ; AU915 20dbm ; CN470 19.15dbm ; EU868 16dbm ; KR920 14dbm ; IN865 20dbm ;
Rx Sensitivity	-136dBm (LoRa, Spreading Factor=12, Bit Rate=293bps) -121dBm (FSK, Frequency deviation=5kHz, Bit Rate=1.2kbps)
Antenna Type	Build-in antenna
Communication Range	Up to 10 km, the actual transmission distance depends on the environment.
Data Transfer Rate	0.3kbps ~ 50kbps (LoRa) 1.2kbps ~ 300kbps (FSK)
Modulation	LoRa/FSK
Available Frequency	EU863-870, US902-928, AU915-928, KR920-923, AS923-1, AS923-2, AS923-3, IN865-867, CN470-510 (Note: optional, to be done in the factory configuration)

Wireless 2-Gang Vibration Sensor, Spring Type

Physical

Dimension	Main Part: L: 112mm*W: 89mm*H: 32mm
Weight	150g
Environment Temperature Range	-20°C ~ 55°C
Environment Humidity Range	< 90% RH (No condensation)
Storage Temperature	-40°C ~ 85°C